

Model : SATELLITE #21500

Spec.Description

1 Product Warranty



Antique Silver - Black



2 Feature

Model	Motor Type	Body Material	Body Color	Blades	Blades Material / Color	Fan Sweep (Diameter)	Control Mode	Lighting
SATELLITE Size : Ø 575x460H	DC	Steel & Leather	Antique Silver Black	3	ABS-BLACK	16.5" / 42 cm.	Remote Control 5 Speed	LED STRIP 30W

LED included

3 Fan Dimension

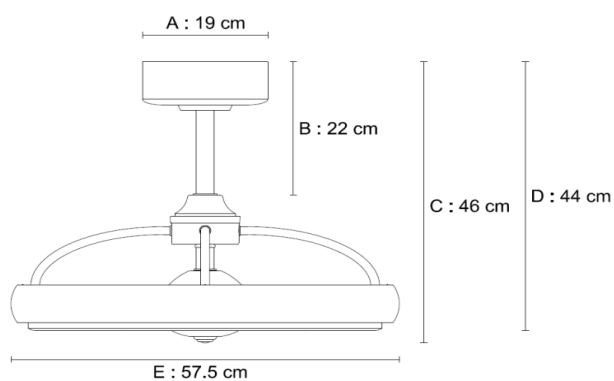

Unit : CM.				
A	B	C	D	E
19	22	46	44	57.5

4 Power Consumption & Efficiency

Speed	Current (A)	Wattage (W)	Motor Speed (RPM)	Air Flow (CFM)	Effeciency (CFM/W)
1	0.1	6.3	370	280	44.44
2	0.13	9.3	440	500	53.76
3	0.17	12.7	510	800	62.99
4	0.25	19.2	580	1200	62.5
5	0.3	24.2	650	1550	64.05

5 Weight/Size (Carton Box)

Gross Weight (Kgs.)	Net Weight (Kgs.)	Size LxWxH (Cm.)	CU.FT	CU.M
9	6.7	66 x 66 x 30.5	4.69	0.13