

Model : ECLIPSE Wood , Matte Black #22000
 : ECLIPSE Antique Silver , Champagne Foil #24900
 : Frame ECLIPSE Wood , Matte Black #7290
 : Frame ECLIPSE Antique Silver , Champagne Foil #7950



Spec.Description

1 Product Warranty



2 Feature

Model	Motor Type	Body Material	Body Color	Frame Color	Blades	Blades Material / Color	Fan Sweep (Diameter)	Control Mode	Lighting
ECLIPSE	DC	Steel	Wood Antique Silver Matte Black Champagne Foil	Wood Antique Silver Matte Black Champagne Foil	3	ABS-Black	22"/56cm	Remote Control 5 Speed	LED STRIP 40W

Size : Ø 690x410H

LED included

3 Fan Dimension

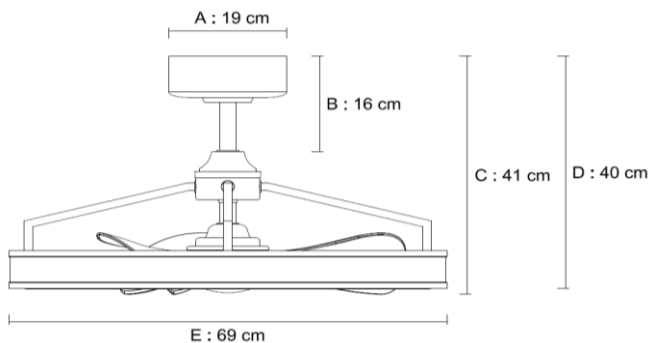

Unit : CM.				
A	B	C	D	E
19	16	41	40	69

4 Power Consumption & Efficiency

Speed	Current (A)	Wattage (W)	Motor Speed (RPM)	Air Flow (CFM)	Effeciency (CFM/W)
1	0.054	2.7	100	650	241
2	0.072	4.3	160	1120	260
3	0.102	6.9	210	1610	233
4	0.156	12	265	2250	188
5	0.253	21	320	2535	121

5 Weight/Size (Carton Box)

Gross Weight (Kgs.)	Net Weight (Kgs.)	Size LxWxH (Cm.)	CU.FT	CU.M
11.7	8.3	77 x 77 x 31.5	6.6	0.19