

Model : STELLAR #26500

Spec.Description

1 Product Warranty



Champagne Foil - Champagne



2 Feature

Model	Motor Type	Body Material	Body Color	Blades	Blades Material / Color	Fan Sweep (Diameter)	Control Mode	Lighting
STELLAR Size : Ø 695x460H	DC	Steel + Aluminium	Champagne Foil	3	ABS-Champagne	22"/56cm	Remote Control 5 Speed	LED STRIP 40W

LED included

3 Fan Dimension

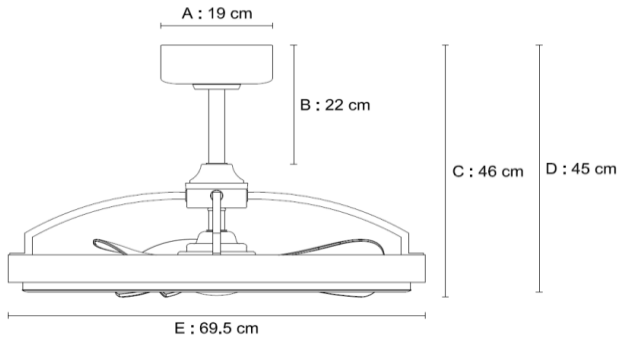

Unit : CM.				
A	B	C	D	E
19	22	46	45	69.5

4 Power Consumption & Efficiency

Speed	Current (A)	Wattage (W)	Motor Speed (RPM)	Air Flow (CFM)	Effeciency (CFM/W)
1	0.054	2.7	100	650	240.741
2	0.072	4.3	160	1120	260.465
3	0.102	6.9	210	1610	233.333
4	0.156	12	265	2250	187.5
5	0.253	21	320	2535	120.714

5 Weight/Size (Carton Box)

Gross Weight (Kgs.)	Net Weight (Kgs.)	Size LxWxH (Cm.)	CU.FT	CU.M
13.3	9.6	78 x 78 x 30.5	6.55	0.19